

Wall fan

VVR31541EC2

VVR31541EC2

Wall fan with radial exhaust – for extraction. The VVR is made of cast aluminium, which provides long durability. VVR can be mounted on wall penetration MGO.



PRODUCT BENEFITS

- Radial exhaust
- High corrosion resistance
- Backward curved blades
- High efficiency

Product description

DESCRIPTION:

The VVR wall fan is an extraction ventilator manufactured in cast aluminium, ensuring long-term, problem-free operation. The MGO wall penetration is available for this, ensuring simple and correct ventilation.

The VVR wall fan has a backward-curved B impeller in aluminium with a radial air exhaust; it can be opened for cleaning. VVR is available in 4 sizes: VVR160, -200, -250, and -315.

MOTORS:

VVR160 and -200 have a single-phase motor, while the other models have an EC motor.

Get an overview of the individual sizes below.

Accessories

Désignations	Variants
MAC12 constant pressure regulator	MAC12
HW050X08002U0UL	EFC1P2
HW050X08002U0UL	MGO315

Fan data

Max. Total efficiency (A-D) (%)	55,1
Ventilation energy class - Average climate	C
Efficiency level requirements	62, N(2015)
ECO efficiency level during optimal operating point	78,0
EC motor	EC motor with integral VSD
Nominal speed (RPM)	1635
Overload protection	Integrated in motor control
Engine power (kW)	0,37

Wall fan

VVR31541EC2**VVR31541EC2****Dimensional data**

A (mm)	365
C (mm)	500
D (mm)	75
Ø B (mm)	525
E Ø (mm)	315
Weight (kg)	29

To ease installation an MGO wall duct can be used with the VVR wall fan.

The MGO is made from galvanised sheeting with 25 mm insulation against sound and condensation. An integral anti-backdraught shutter is included and the duct can be adjusted to lengths from 210 - 400 mm, to match the thickness of the wall. MGO can be mounted together with diffuser (1), inlet sleeve ILMF and cover flange MGAF as shown below.

INSTALLATION SOLUTION 1

If a MGO terminates flush with the internal wall, a covering flange (MGAF) and inlet sleeve (ILMF) must be fitted before the diffuser is fitted (1).

INSTALLATION SOLUTION 2

If the (MGO) is shorter than the wall's thickness, an inlet (ILU) and sleeve (MF) or a spiro tube (SR) must be fitted before the diffuser (1) is fitted.

INSTALLATION SOLUTION 3

If there is a long distance between the MGO and the exhaust location, an ILU inlet connected to SR spiral tube must be mounted.

Electrical datas

Frequency (Hz)	50
Max. current (A)	2,6
Max. power	0,43
Engine power (kW)	0,37
Motor 1 x230 V Amp/kW	2,6 / 0,37

Regulatory data

Ventilation energy class - Average climate	C
--	---

Installation

VVR is made from cast aluminium, giving it a high corrosion resistance (corrosion class C4 in accordance with EN ISO 12944-2). It is painted in black RAL7021.



VVR is an extract fan with a vertical exhaust.

The design ensures an optimum air handling solution with minimum noise.



VVR wall fan is ideal for ventilation tasks requiring efficient and economical ventilation.

The specially developed centrifugal impeller with backward curved blades ensures high efficiency and low operating costs.

Wall fan

VVR31541EC2

VVR31541EC2



If there is a high level of humidity in the extract air, the VVR wall fan can be ordered with a guide panel.

The guide panel ensures that moisture does not run down the wall but is guided away from it.

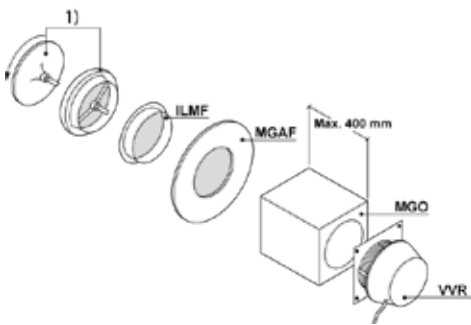

To ease installation an MGO wall duct can be used with the VVR wall fan.

The MGO is made from galvanised sheeting with 25 mm insulation against sound and condensation. An integral anti-backdraught shutter is included and the vent can be adjusted to lengths from 210 - 400 mm, to match the thickness of the wall. The MGO can be mounted together with a diffuser (1) inlet sleeve ILMF and cover flange MGAF as shown below.

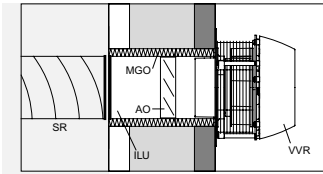

INSTALLATION SOLUTION 3

If there is a long distance between the MGO wall duct and the exhaust location, an ILU inlet connected to SR spiral tube must be mounted.

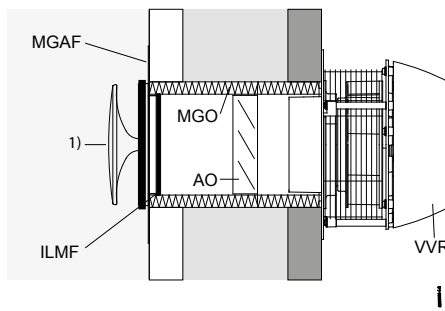

INSTALLATION SOLUTION 1

If a wall duct (MGO) terminates flush with the internal wall, a covering flange (MGAF) and inlet sleeve (ILMF) must be fitted before the diffuser is fitted (1).

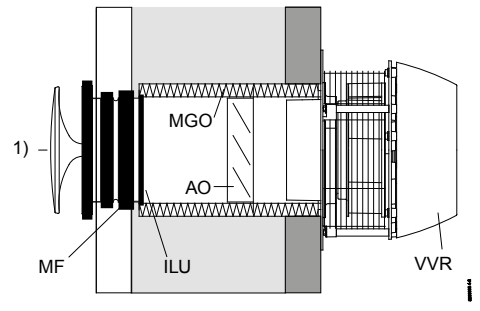

Mounting solution 2

If the MGO is shorter than the thickness of the wall, an inlet (ILU) and sleeve (MF) or spiral pipe (SR) must be installed, to which the diffuser (1) is attached.

Wall fan

VVR31541EC2

VVR31541EC2



VVR is available with 2 motor types:

- > Single-phase AC motor
- > EC-motor

The motors are made to protection class IP54 and all materials are as a minimum class F (155 °C). The motor has integral current overload protection.

Curve

