

## CMEV air handling unit

### VEX330T

#### VEX330T

VEX300T is an extremely compact unit with top connection and optimal energy performance, with low sound or noise levels to the surroundings.



#### PRODUCT BENEFITS

- Transport through 900-mm door possible
- High efficiency (up to 90%) AHU units
- Exclusive Aldes Smart Control System

#### REGLEMENTATIONS AND COMPLIANCES

Eurovent Certification no. : 10.12.505

#### Principles of operation

The VEX 300T brings fresh, filtered air into the building and recovers heat from exhaust air using its high-efficiency heat exchanger. The incoming air can be heated and/or cooled using a comprehensive range of coils.

#### Product description

VEX300T is a range of compact air handling units in which all ducts exit the top of the unit. Water is also connected to the cooling/heating surface placed in the top of the air handling unit, just as the condensation outlet is connected on the front of the unit. Therefore, VEX300T can be placed closely to other technical equipment, since the end walls do not need to be accessed for service.

The range consists of 5 sizes, with an option for the EXact2 control system or prepared for a third party control system.

VEX300T has been constructed with integral heating or cooling coils, which reduces the installation costs. It is also possible to choose filtration of the supply air.

The design is optimised for compactness, temperature efficiency, airflow and energy consumption. Despite being very compact in size, the unit is easy to service, e.g. for filter change, cleaning, etc.

#### Installation

- VEX300T must be located indoors and can be used for all purposes where the special top-duct construction will aid installation.

#### Main characteristics

- 1 decentralised model - up to 850 m<sup>3</sup>/h - in 2 versions:
  - visible version (STD),
  - semi-integrated version (INT) for installation in a suspended ceiling.
- Monoblock construction,
- insulation - 20 mm polyurethane for better noise attenuation,
- external finish: Aluzinc AZ185: class C4 anti-corrosion performance. Can be customised in pre-painted white (standard), anthracite grey, gold on request,
- vertical attachments for connection to ceiling or horizontal attachments for wall-mounted connections,
- EC motor and forward curve impeller,
- high efficiency counterflow heat exchanger (Eurovent AAHE),
- adjustable by-pass,
- ePM10 60% (M5) or ePM1 55% (F7). Coarse 60% (G4) pre-filters as accessory,
- accessories:
  - built-in CO<sub>2</sub> sensor,
  - built-in motion sensor with LED status indicator - PIR,
  - built-in humidity sensor - HR,
  - communication with webserver - WEBE,
  - HMI user interface (for start-up and commissioning),
  - caution: if the built-in CO<sub>2</sub> sensor and the built-in PIR are selected, the unit is fully ready for use.

## CMEV air handling unit

**VEX330T****VEX330T****Supplementary characteristics**

- Extremely compact design with top connection
- Integrated cooling/heating coil
- Very quiet product, emits minimal noise to the surroundings

**Accessories**

Désignations	Variants
SIPHONUP SR1K1 SR1K3	SIPHONUP
Syphon heating electric heating wire, 2 metres	SIPHONHE02
Airflow control for VEX300T with Exact AFC320C AFC330C	AFC2V300T
Closing damper, Ø315	LS31524
Closing damper with spring-return, Ø 315 mm	LSR31524
Base for VEX320T	MSV320T
Modbus communications module for analogue and digital inputs and outputs	MIO
Manual override timer button	TIMERBUTTON
Manual override to comfort mode excl. MIO - incl. cable	TIMERBUTTON2
Motion sensor for override at comfort level (MIO)	PIRB-AS
Motion sensor for override at comfort level (Modbus)	MIOPIR
HW050X08002U0UL	MIOTSRROOM
Temperature sensor for duct incl. modbus communications module	MIOTSDUCT
CO2 sensor – room (MIO)	MIOCO2ROOM
CO2 sensor duct (MIO)	MIOCO2DUCT
RH sensor, room (MIO RH-ROOM)	MIORHROOM
Touch panel 3.5	MHI2-350-TOUCH
Pressure sensor for constant pressure regulation	MPTDUCT
CO2 room sensor analogue 0–10 V (can be reprogrammed)	CO2ROOM
CO2 room sensor analogue 0–10 V	RCO2
HW050X08002U0UL	RCO21000
CO2 duct sensor analogue 0–10 V (reprogrammable)	CO2DUCT
CO2 duct sensor analogue 0–10 V	KCO2
HW050X08002U0UL	KCO21000
Air quality sensor - excl. MIO	RLQ
MIO2 module	MIO2-MODUL
Motion sensor - digital - excl. MIO	PIR
RH sensor for room - analogue 0-10 V (0-100 % RH)	RFF
Syphon water trap, overpressure	SIPHONOP

**General data**

Motor class in accordance with IEC TS 60034-30-2	IE4 (Super Premium Efficiency)
Voltage input	1 x 230 V
Regulation	Variable via motor control (MC)
Control signal with control system	Modbus
Control signal with third party control system	0-10 V DC
Fluid temperature (air)	-40°C...+40°C
Ambient temperature range	-30°C...+50°C

**Fan data**

Max. Total efficiency (A-D) (%)	60
Efficiency level requirements	62N (2015)
ECO efficiency level during optimal operating point	79,4N
Overload protection	Built-in

#### CMEV air handling unit

## VEX330T

### Dimensional data

A (mm)	1474
B (mm)	1092
C (mm)	1500
D (mm)	932
E (mm)	827
Ø connection (fresh air or exhaust) (mm)	315
Ø connection (discharge or air supply) (mm)	315
Weight (kg)	265
Weight for transport	158 kg (excl. doors, heat exchanger and fans)

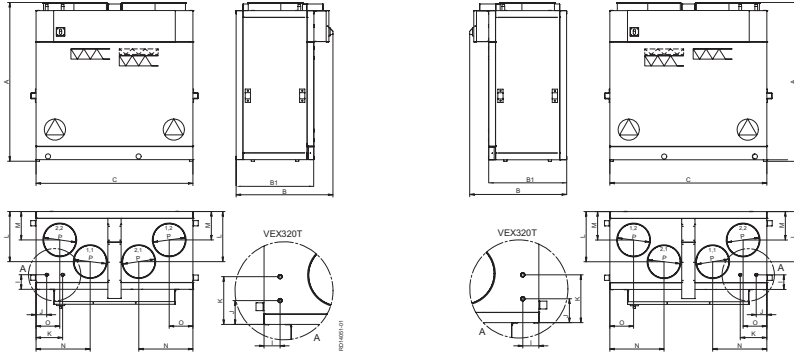

### Airflow data

Minimum airflow	200
Max. airflow ErP (m³/h)	1775
Max. airflow (m³/h)	2150

### Heat recovery data

Max. exchanger output (%)	94
---------------------------	----

### Electrical datas

Frequency (Hz)	50
Max. current consumption SINGLE-PHASE 230 V (A)	7,3
Max. power of electrical coil 1 (kW)	10.41
Max. electrical output of unit (kW)	1,7
Voltage (V)	1x230
Electrical coil voltage 1	3x400
Maximum current - unit (A)	7,3
Power consumption (kW)	0,457

### Regulatory data

Test values as per standard EN 1886	D2, L1, L1, F9, T2, TB3
-------------------------------------	-------------------------

## CMEV air handling unit

**VEX330T****VEX330T**

## Installation



VEX330T is equipped with an optimised centrifugal impeller with backward curved blades. The wheel is made from a composite material and its shape provides great performance with low energy consumption.

Cabinets are made from Aluzinc® AZ185 class C4 in accordance with EN/ISO12944-2 and insulated with 50 mm mineral wool. This results in low noise emissions to the surrounding environment/installation room. The panel design minimises the formation of thermal bridges in the unit.

The motor sections are mounted in vibration dampers, which reduces noise in the ducts and eliminates the need to fit flexible connections between the unit and the duct system. The motors are of type EC and are extremely efficient. They comply with the requirements of the Ecodesign Directive.



The VEX330T range is supplied with an integral heating coil or cooling-heating coil

HE: Electric heating coil (requires airflow control, accessory - AFC)

HW: Water heating coil

CW: Cooling-heating coil (option for cooling in summer and heating in winter)

DX: Cooling-heating coil (option for cooling in summer and heating in winter)

See more about cooling/heating coils under the technical data for the size in question.

Note: It is also possible to order the VEX330T without cooling and/or heating coils



The easily accessible connection box with built-in isolator switch and control fuses ensures easy access for connection and adjustment. Read more about electrical connection in the guide "Electrical guide for VEX310-350T"



Panel filters for supply air and extract air – the filters are easy to replace.

The filters are available in the following filter classes: ePM1 80% (F9), ePM1 55% (F7), ePM10 65% (M5) and Coarse 65% (G4).

See filter size under technical data for the individual VEX size.

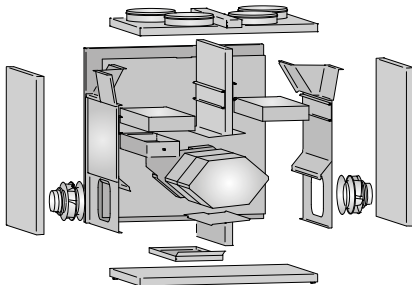

With some projects, limited space means that internal transport of the air handling unit is difficult or impossible. This is why the VEX330T is available as a SPLIT version. It means that the air handling unit can be assembled and tested at the factory as normal – just without sealant. The air handling unit can therefore be easily taken apart at the installation site, transported as single sections, assembled, sealed and commissioned.



It is possible to insert a 48-mm filter ahead of the standard filter on the supply air side. Placing a coarser filter in front of a finer filter reduces soiling on the finer filter. Depending on the outdoor air and the desired quality of the supply air, this can be a good idea/option.

The filters for pre-filtration are available in the following filter classes: ePM1 55% (F7), ePM10 65% (M5) and Coarse 65% (G4).

Pressure drop, etc. can be calculated in the product selection programme EXselectPRO.

CMEV air handling unit

**VEX330T**  
VEX330T

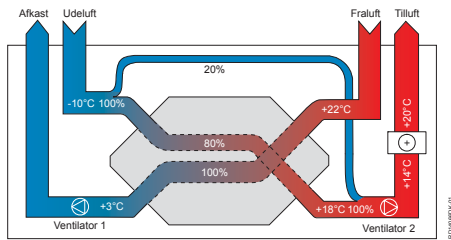

The VEX300T is designed with de-icing bypass. If there is a risk of icing, then a certain amount of outdoor air will bypass the heat exchanger and go directly to the after heating coil. This increases the demands on the heating coil's output. However, it avoids a costly preheating coil. The drawing below is an example of a de-icing situation, where 20% of outdoor air is directed through the bypass damper.

Heating coil and de-icing function:

The de-icing situation is shown above, a heating coil is included here. This is completely necessary, in order for the de-icing function to function correctly. Without the heating coil, the de-icing process will cause the temperature of the supply air to fall and sooner or later the VEX unit will stop because of icing.

The heat exchanger has two forms of frost protection: temperature-controlled or pressure-controlled.

The actual de-icing can take place in several ways, depending on whether an after heating coil has been fitted. A post-heat surface is always recommended to maintain continuous ventilation.

The control system has temperature-controlled frost protection as standard. It is an inexpensive solution and provides sufficient frost-protection in some situations.

A temperature sensor is fitted inside the heat exchanger and if the temperature falls to a pre-set value, de-icing begins. This temperature level is factory set to 0 °C but it can also be changed to a new value via the control system.

Temperature-controlled frost protection triggers the de-icing process even if there is no ice in the heat exchanger.

The control system monitors the actual airflow and also the pressure drop across the heat exchanger. If ice forms in the heat exchanger, the pressure drop across the heat exchanger will increase and when it exceeds a pre-set value, de-icing begins. Pressure-controlled frost protection only starts de-icing when ice has actually formed, regardless of whether there are sub-zero temperatures.

> Aldes Smart Control®/EXcon control (France, Norway, Sweden):

- constant speed
- constant airflow
- constant pressure
- airflow control via CO2/VOC sensor (0–10V signal).
- Controlled pressure
- built-in clock: operating hours can be controlled with timer
- wired remote control system
- BMS communication via Modbus RTU and Bacnet TCP/IP protocols

> EXact2 control system (other countries):

- Constant speed. - Variable speed. - Constant pressure
- Airflow control with CO2/VOC sensor (0–10 V signal)
- Wired remote control system
- Option: Built-in web server
- Option: BMS communication via Modbus RTU/RS485, Modbus TCP/IP, BACnet, MSTP/BACnet IP

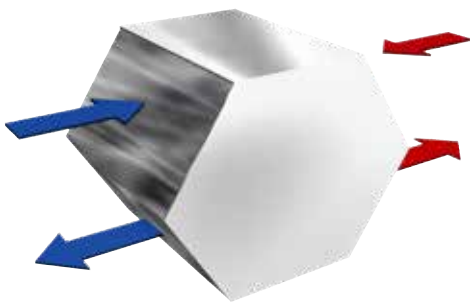

The counterflow heat exchanger in VEX300T is made of aluminium. Its design ensures the ratio between heat recovery and pressure drop is optimally distributed.

I.e. extremely high temperature efficiency is achieved at low levels of energy consumption.

- > 80-85% efficiency without condensation
- > Up to 94% efficiency with condensation



The combination of a modern EC motor and an optimised centrifugal impeller delivers extremely low energy consumption and greater output at the same time.

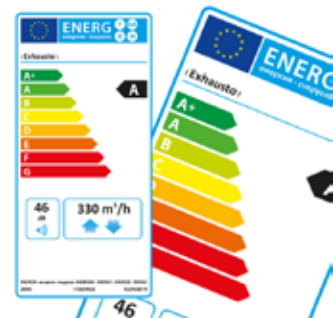

An energy label that states the energy class of the air handling unit in relation to defined operating conditions is available via our product calculation programs.

**Principles of operation**

VEX330T operatin

CMEV air handling unit

## VEX330T

VEX330T

Curve

