

1 CENTRALIZED VENTILATION

Roof fan

SEF40043

SEF400

Fire gas fan for roof. Approved for temperatures up to 400°C for 120min (400/2H) and approved as both operating and evacuation fan in accordance with EN12101-3:2015.



PRODUCT BENEFITS

- Certified combustion gas fan (smoke exhaust extractor) F400/2H
- Approved for 400°C in 120 min.
- Operations and evacuation fan

Product description

SEF combustion gas fan with vertical exhaust is approved for temperatures up to 400°C for 120 min.

SEF and TGKS roof cowl has been tested and approved as a general operations fan and evacuation fan in accordance with EN12101-3:2015. Certificate: 0402-CPD-453701.

SEF is made of die-cast aluminium and surface treated with hammer varnish, which makes it light, mechanically strong and extremely resistant to corrosion (Corrosion class C4 according to EN ISO 12944-2).

The motor is a temperature resistant, sealed asynchronous motor with lifetime lubricated ball bearings. This ensures a long service life, high efficiency and low noise levels.

SEF is supplied as standard with vibration damper, armoured cable, mineral wool mat and safety screws which ensure the fan stays attached to the roof cowl whatever the weather or conditions.

Accessories

Désignations	Variants
MAC12 constant pressure regulator	MAC12

Dimensional data

A (mm)	430
E (mm)	130
Ø D (mm)	400
Weight (kg)	44

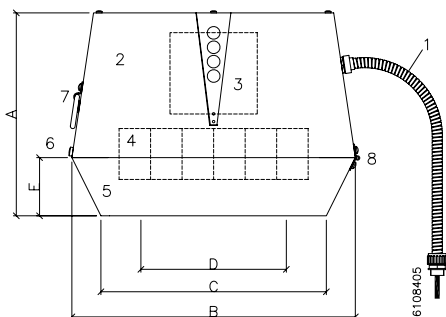

Electrical datas

Motor 3 x 400 V Amp/kW	1,3 / 0,42
------------------------	------------

Roof fan

SEF40043**SEF400****Installation**

The fan is fitted onto the roof cowl using the supplied vibration dampers. This ensures vibration-free operation, while the mineral wool mat positioned on the spigot forms a seal between the fan and the roof cowl. The safety bolts are fitted in the roof cowl.

The TGKS roof cowl is composed of galvanised sheet metal, 50 mm mineral wool that insulates against sound and condensation, mesh, and an inner housing of perforated galvanised sheet metal.

SEF can also be mounted on an existing roof cowl using an FPTS mounting panel.



The fan is fitted onto the roof cowl using the supplied vibration dampers. This ensures vibration-free operation, while the mineral wool mat positioned on the spigot forms a seal between the fan and the roof cowl. The safety bolts are fitted in the roof cowl.

The TGKS roof cowl is composed of galvanised sheet metal, 50 mm mineral wool that insulates against sound and condensation, mesh, and an inner housing of perforated galvanised sheet metal.

SEF can also be mounted on an existing roof cowl using a FPTS mounting panel.

Curve